

WASCOMAT "SUPER" 140 G-FORCE OPL WASHER MODELS

High-extract, efficient, automatic, professional washers

Wascomat commercial, solid-mount, high-extract
"Super" washer models save water, energy and labor, cut drying time
for big gas savings and increase laundry productivity.
Ideal for any in-house and commercial laundry installations.



SU620s / 20 lb. cap. SU630c / 30 lb. cap. SU640s / 40 lb. cap. SU655s / 55 lb. cap. SU675c / 75 lb. cap.

"Super" Washer Models Features and Benefits. Available with Selecta20® or Clarus® Wash Cycle Control.

- Inverter drive motor for wash or extract speed selection.
- Hooks up to 3 phase or single phase power supply.
- Large door opening for easy loading and unloading.
- Unibody construction eliminates welds for superior strength, reliability and durability.
- Interchangeable parts from one size and model washer to another.

Unique 4-Compartment Supply Dispenser

Accepts liquid or powder detergents, bleach and fabric softener for superior wash results. Provision to connect liquid supply injector on back of washer.



- 1 Easy service access.
- 2 Automatic four-compartment supply dispenser.
- 3 UPC compliant venting for backflow prevention.
- 4 Triple-seal, extra heavy-duty bearing and seal system.
- 5 High-grade stainless steel inner and outer drums.
- 6 State-of-the-art riveted, no-weld, galvanized steel base frame prevents weld cracks and rust.
- 7 A choice of state-of-the-art, menu-driven microprocessor Selecta20® or Clarus® wash cycle control.
- 8 Heavy duty door and hinges designed for heavy use.
- 9 Large door opening for easy loading and unloading.
- 10 Door lock system unlocks immediately at the end of wash cycle.
- 11 Reliable, easy to clean, front accessible, water-operated drain valve reduces water consumption and clogs.

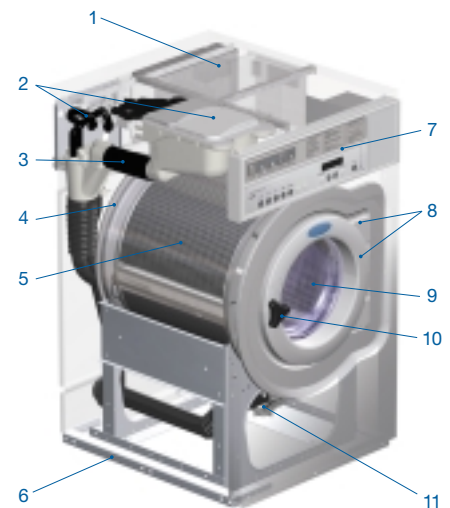

Choice of front panel colors: almond, teal green, white or stainless steel option.

Wascomat Laundry Equipment

The Standard of Quality for Over 100 Years!

Technical Specifications

| Model | SU620 | | SU630 | | SU640 | | SU655 | | SU675 | |
|--|-----------|-----------|-----------|-----------|------------|-----------|------------|-----------|------------|-----------|
| Capacity (lb/kg) | 20 | 8.5 | 30 | 13 | 40 | 18 | 55 | 25 | 75 | 34 |
| Width (in/mm) | 26 | 660 | 28 3/8 | 720 | 29 1/2 | 750 | 32 11/16 | 830 | 35 13/16 | 910 |
| Depth (overall) (in/mm) | 30 1/8 | 765 | 32 1/2 | 825 | 36 | 915 | 39 | 990 | 42 5/16 | 1075 |
| Height (in/mm) | 43 7/8 | 1115 | 47 1/4 | 1200 | 52 3/16 | 1325 | 55 1/2 | 1410 | 56 7/8 | 1445 |
| Crated width - (in/mm) | 27 3/16 | 690 | 29 1/2 | 750 | 30 11/16 | 780 | 33 7/8 | 860 | 37 | 940 |
| Crated depth - (in/mm) | 32 11/16 | 830 | 35 1/16 | 890 | 39 3/16 | 995 | 43 11/16 | 1110 | 47 1/16 | 1195 |
| Crated height - (in/mm) | 48 | 1219 | 51 5/16 | 1304 | 56 7/16 | 1434 | 61 1/4 | 1556 | 62 7/16 | 1586 |
| Height to bottom of door (in/mm) | 14 | 355 | 14 3/8 | 365 | 17 1/8 | 435 | 19 1/2 | 495 | 19 11/16 | 500 |
| Door opening diameter (in/mm) | 12 3/16 | 310 | 14 3/8 | 365 | 15 9/16 | 395 | 17 1/8 | 435 | 17 1/8 | 435 |
| Cylinder volume (ft ³ /l) | 3.0 | 85 | 4.6 | 130 | 6.4 | 180 | 8.8 | 250 | 11.7 | 330 |
| Cylinder diameter (in/mm) | 20 1/2 | 520 | 23 7/16 | 595 | 25 9/16 | 650 | 28 9/16 | 725 | 31 5/16 | 795 |
| Cylinder depth (in/mm) | 16 5/16 | 414 | 18 7/16 | 468 | 21 5/16 | 542 | 23 7/8 | 606 | 26 3/16 | 665 |
| Drain outlet diameter (in/mm) | 3 | 75 | 3 | 75 | 3 | 75 | 3 | 75 | 3 | 75 |
| Height to centerline of drain (in/mm) | 3 15/16 | 100 | 3 15/16 | 100 | 3 15/16 | 100 | 3 15/16 | 100 | 3 15/16 | 100 |
| Height to electrical connection (in/mm) | 32 1/2 | 825 | 35 13/16 | 910 | 40 3/4 | 1035 | 44 1/8 | 1120 | 45 1/2 | 1155 |
| Height to water connections (in/mm) (approx) | 40 9/16 | 1030 | 43 7/8 | 1115 | 49 | 1245 | 52 3/8 | 1330 | 53 3/4 | 1365 |
| Dynamic load (lb/kN) | 270+/-585 | 1.2+/-2.6 | 382+/-832 | 1.7+/-3.7 | 495+/-1057 | 2.2+/-4.7 | 630+/-1304 | 2.8+/-5.8 | 854+/-1551 | 3.8+/-6.9 |
| Dynamic frequency (Hz) | 11.6 | | 10.8 | | 10.3 | | 9.8 | | 9.4 | |
| Noise level (dBA) | 65 | | 72 | | 74 | | 74 | | 74 | |
| Net wt (lb/kg) | 300 | 136 | 403 | 183 | 452 | 205 | 622 | 282 | 657 | 298 |
| Crated weight (lb/kg) | 331 | 150 | 432 | 196 | 489 | 222 | 666 | 302 | 701 | 318 |

Operating Speeds

| | | | | | | | | | | |
|-----------------------|-----------|--|-----------|--|-----------|--|-----------|--|-----------|--|
| Wash (rpm) | 52 | | 49 | | 44 | | 44 | | 42 | |
| Extract (rpm/G-Force) | 694 / 140 | | 649 / 140 | | 619 / 140 | | 587 / 140 | | 561 / 140 | |

Electrical Requirements (standard)

| | | | | | | | | | | |
|---|--------------|--|--------------|--|--------------|--|--------------|--|--------------|--|
| Voltage/frequency/phase | 208-240/60/1 | | 208-240/60/1 | | 208-240/60/1 | | 208-240/60/1 | | 208-240/60/1 | |
| Full-load current (Amps) / Ckt breaker (Amps) | 2.7 / 15 | | 3.4 / 15 | | 3.7 / 15 | | 7.3 / 15 | | 7.3 / 15 | |

Water Information

| | | | | | | | | | | |
|--------------------------------------|-------|---------|-------|---------|-------|---------|-------|---------|-------|---------|
| Inlet fittings (* = 2 cold inlets) | DN20 | 3/4 | DN20 | 3/4 | DN20* | 3/4* | DN20* | 3/4* | DN20* | 3/4* |
| Flow (gpm/lpm @ 45 psi) (each inlet) | 5 | 20 | 5 | 20 | 5 | 20 | 16 | 60 | 16 | 60 |
| Recommended water pressure (psi/kPa) | 30-90 | 200-600 | 30-90 | 200-600 | 30-90 | 200-600 | 30-90 | 200-600 | 30-90 | 200-600 |

Refer installation and servicing to qualified, licensed personnel. Always read installation and operating manuals and consult local codes before installation. Protect machines with properly rated, common-trip, circuit breakers ONLY. Warranty void if not properly installed. Solid-mount machines require a custom concrete foundation, and are not suitable for upper-floor or above-basement installations. Contact Wascomat for more information and for availability of machines for electric services not listed. Specifications subject to change without notice. Wascomat assumes no responsibility for errors or omissions in this information.

Choice of Wash Cycle Control



CLARUS®

Fully programmable menu-driven microprocessor control provides nine standard wash programs and the ability to create over 192 individual custom programs.



SELECTA20®

Microprocessor control with 20 different built-in programs for hotels, nursing homes, health care and diaper services.

For more information on the full line of Wascomat washers, dryers, flatwork ironers and low-cost financing and leasing, call Wascomat toll free today.

Wascomat Laundry Equipment

1-800-645-2204 • www.wascomat.com

461 Doughty Blvd., Inwood, L.I., N.Y. 11096-0338
 Sales and Administration – Tel: 516-371-4400 • Fax: 516-371-4204 • e-mail: sales@wascomat.com
 Spare Parts – Tel: 516-371-2000 • Fax: 516-371-4029 • e-mail: parts@wascomat.com
 Technical Support – Tel: 516-371-0700 • Fax: 516-371-4029
 En Mexico: Llame gratis a este numero 001-800-010-1010



Your local independent authorized dealer

