

WASCOMAT EXTRACT-O-MATIC SOFT-MOUNT WASHERS

Advanced Technology in 15 lb. to 50 lb. Capacity,
Variable Speed, High G-Force Extract Washers

Ideal for any OPL application:

Hotels	Shirt Laundries	Schools & Colleges
Motels	Cleaners	Athletic Clubs
Nursing Homes	Health Clubs	Commercial Laundries
Hospitals	Restaurants	Institutional Laundries



Designed and built for the 21st Century!



EX618s: 18 lb. Capacity.
Up to 350 G-force.

EX625s: 25 lb. Capacity.
Up to 350 G-force.

EX630c: 30 lb. Capacity.
Up to 350 G-force.

EX640c: 40 lb. Capacity.
Up to 350 G-force.

EX655c: 55 lb. Capacity.
Up to 350 G-force.

Choice of user-friendly, state-of-the-art Controls

Clarus Control™



Fully programmable microprocessor-driven control menu provides nine standard wash programs and the ability to create over 192 individual custom programs. Large display, simple menu systems and few buttons. Programmable memory cards can be used to start or install programs created on your computer or on the control panel.

Selecta20™



Preprogrammed microprocessor with 20 different built-in custom programs for hotels, nursing homes and diaper/health care. Pushbutton simplicity requires no skills - just press your program and START - fully automatic!

Features	● standard	○ options	- not available	EX618s	EX625s	EX630c	EX640c	EX655c
Choice of control:								
• Clarus™ microprocessor for user programming of up to 192 programs and 9 fixed programs, service program and statistics								
• Selecta™ microprocessor with 20 wash programs and a built-in service program								
FC-motor for smooth and efficient wash and extraction cycle	●	●	●	●	●	●	●	●
High grade 18/8 stainless steel in drum and front panels	●	●	●	●	●	●	●	●
Hot dip galvanized steel bars	●	●	●	●	●	●	●	●
Soft mount suspended construction	●	●	●	●	●	●	●	●
High speed extract selection	●	●	●	●	●	●	●	●
Safe water operated drain valve	●	●	-	-	-	-	-	-
AWS Automatic Weighing System ensures a minimum consumption of water	●	●	○	○	○	○	○	○
User-friendly sturdy door design	●	●	●	●	●	●	●	●
Prepared for connection to 5 liquid detergents	-	-	●	●	●	●	●	●
Options								
Extra drain valves for re-use of water or solvent	-	-	○	○	○	○	○	○
Wetclean version	-	○	○	○	○	○	○	○
DBS Dynamic Balancing System to reduce noise transmission	-	-	○	○	○	○	○	○

s = Selecta20™ Control c = Clarus Control™

Wascomat Laundry Equipment

The Standard of Quality for Over 100 Years!

Technical Specifications

Model	EX618		EX625		EX630		EX640		EX655	
Capacity (lb/kg)	18	8.2	25	11.4	30	13.6	40	18.2	55	25
Width - A (in/mm)	28 3/8	720	32 11/16	830	35 13/16	910	38 3/16	970	40 3/16	1020
Depth - B (in/mm)	27 3/16	690	27 3/4	705	30 7/8	785	34 1/4	870	36	915
Depth (overall) - C (in/mm)	28 3/8	720	30 1/8	765	32 1/2	825	37	940	38 13/16	986
Height - D (in/mm)	43 7/8	1115	47 1/4	1200	52 3/16	1325	55 1/2	1410	56 7/8	1445
Crated width - (in/mm)	30 5/16	770	34 5/8	880	37 13/16	960	40 3/16	1020	42 1/8	1070
Crated depth - (in/mm)	31 7/8	810	32 1/2	825	35 13/16	910	40 9/16	1030	42 1/8	1070
Crated height - (in/mm)	49	1245	52 3/8	1330	57 5/16	1455	60 5/8	1540	62	1575
Height to bottom of door - E (in/mm)	14	355	14 3/8	365	17 1/8	435	18 1/2	470	19 11/16	500
Door opening diameter (in/mm)	12 3/16	310	14 3/8	365	15 9/16	395	17 1/8	435	17 1/8	435
Cylinder volume (ft ³ /l)	2.6	75	3.7	105	4.6	130	6.4	180	8.5	240
Cylinder diameter (in/mm)	20 1/2	520	23 7/16	595	25 9/16	650	28 9/16	725	31 5/16	795
Cylinder depth (in/mm)	13 7/8	353	14 7/8	378	15 7/16	392	17 1/8	435	19 1/16	484
Drain outlet diameter (in/mm)	3	75	3	75	3	75	3	75	3	75
Centerline of drain - F (in/mm)	3 15/16	100	3 15/16	100	3 15/16	100	3 15/16	100	3 15/16	100
Centerline of drain - G (in/mm)	9 7/16	240	11 5/8	295	12	305	13 3/16	335	14 3/16	360
Electrical connection - H (in/mm)	32 1/2	825	35 13/16	910	40 3/4	1035	44 1/8	1120	45 1/2	1155
Electrical connection - J (in/mm)	1 3/4	45	1 3/4	45	4 15/16	125	4 1/2	115	3 15/16	100
Water connections - K (in/mm) (approx)	39 3/4	1010	43 5/16	1100	48 1/4	1225	50 13/16	1290	52 3/16	1325
Water connections - L (in/mm) (approx)	7 1/16	180	7 1/16	180	11 13/16	300	11 13/16	300	11 13/16	300
Dynamic load (lb/kN)	+/- 112	+/- 0.5	+/- 112	0.5	+/- 112	0.5	+/- 225	+/- 1	+/- 225	+/- 1
Dynamic frequency (Hz)	18.3		17.1		16.4		15.5		14.8	
Noise level (dBA)	71		73		73		80		80	
Net wt (lb/kg) (w/o options)	353	160	447	203	463	210	500	227	540	245
Crated weight (lb/kg) (w/o options)	383	174	480	218	498	226	560	254	580	263
Operating Speeds										
Wash (rpm)	52		49		49		44		42	
Extract (rpm/g factor) (max)	1100 / 350		1025 / 350		980 / 350		930 / 350		890 / 350	
Electrical Requirements (standard)										
Voltage/frequency/phase	208-240/60/1									
Full-load current (Amps) / Ckt breaker (Amps)	5.2 / 15		5.2 / 15		5.6 / 15		10 / 15		10 / 15	
Alternate Voltages										
Voltage/frequency/phase-breaker (rating)	440/60 (10A)		440/60 (10A)		440/60 (10A)		440/60 (15A)		440/60 (15A)	
Water information										
Inlet fittings (* = 2 cold inlets)	3/4	DN20	3/4	DN20	3/4	DN20	3/4	DN20	3/4	DN20
Flow (gpm/lpm @ 45 psi) (each inlet)	5	20	5	20	5	20	5	20	16	60
Recommended water pressure (psi/kPa)	30-90	200-600	30-90	200-600	30-90	200-600	30-90	200-600	30-90	200-600
Steam supply* (psi/kPa)	40-90	300-600	40-90	300-600	40-90	300-600	40-90	300-600	40-90	300-600
Steam inlet *	1/2	DN15	1/2	DN15	1/2	DN15	1/2	DN15	1/2	DN15

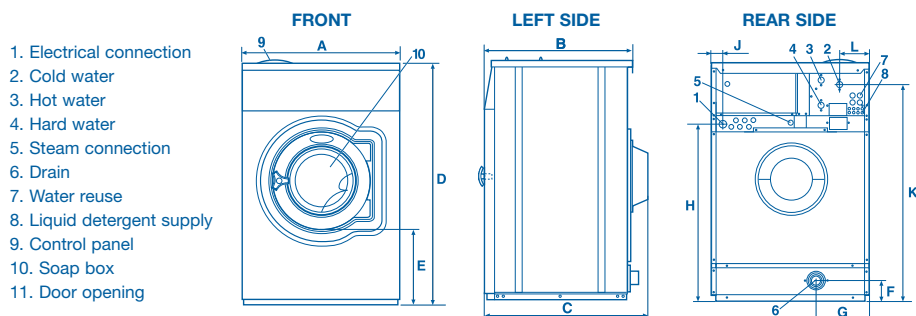

* Steam supply required only for steam-heated models. Refer installation and servicing to qualified personnel. All models equipped with energy-efficient inverter motor drive system. Always consult local codes before installation. Protect machines with properly rated, inverse-time, common-trip, industrial-type circuit breakers ONLY. Contact Wascomat for more information and for availability of machines for electric services not listed. Specifications subject to change without notice. Wascomat assumes no responsibility for errors or omissions in this information. Consult a qualified engineer to determine suitability for other than ground floor installations.



For more information on the full line of Wascomat washers, dryers and low-cost financing, call Wascomat toll free today.

Wascomat Laundry Equipment

1-800-645-2204 • www.wascomat.com

461 Doughty Blvd., Inwood, L.I., N.Y. 11096-0338
 Sales and Administration – Tel: 516-371-4400 • Fax: 516-371-4204 • e-mail: sales@wascomat.com
 Spare Parts – Tel: 516-371-2000 • Fax: 516-371-4029 • e-mail: parts@wascomat.com
 Technical Support – Tel: 516-371-0700 • Fax: 516-371-4029
 En Mexico: Llame gratis a este numero 001-800-010-1010

Your local independent authorized dealer

